

Rounding corners of gearlike domains and the omitted area problem

Roger W. BARNARD and Kent PEARCE

Department of Mathematics, Texas Tech University, Lubbock, TX 79409, U.S.A.

Received 22 January 1984

Revised 1 September 1984

Abstract: A function g analytic on the open unit disk \mathcal{D} and vanishing only at the origin is said to be gearlike if g maps \mathcal{D} to a domain whose boundary consists of arcs of circles centered at the origin and segments of rays emanating from the origin.

The authors discuss each of the possible types of (boundary) corners the image domain of gearlike functions may have and give formulae for rounding or smoothing each of these possible corners, extending some early work of P. Henrici.

The omitted area problem, first posed by Goodman in 1949, is to determine for a normalized univalent analytic function f on \mathcal{D} the maximum area in \mathcal{D} which can be omitted from the range of f . While Goodman gave some early bounds for the maximal omitted area, the problem has generally proved to be one of the difficult and long outstanding problems in geometric function theory. The authors apply the method of rounding corners to a specifically constructed gearlike function to produce an approximation for the extremal solution.

Keywords: Curvilinear Schwarz–Christoffel maps, rounding corners, omitted area problems.

1. Introduction

In this paper we discuss gearlike domains, rounding corners for these domains, and an application to a long-standing problem (the omitted area problem) in geometric function theory. Gearlike domains were introduced by Goodman [4] to help in the study of logarithmic derivatives of potentials represented in the complex plane. Because of the relative obscurity of the journal containing Goodman's results on gearlike domains, we repeat here some of the ideas developed by him. Our results, however, apply to a wider class of problems.

The application we give of rounding corners of gearlike domains to the omitted area problem was motivated by a characterization given by the first author for an extremal solution of this problem. We note that the formulae given by Henrici [8] suggest the methods we will use; however, Henrici's formulae are not directly applicable to gearlike domains due to the introduction of the logarithmic derivative and the requirement that the particular boundary behavior be preserved away from the corners being rounded. Therefore, we develop general formulae for rounding each of the possible types of corners that occur in gearlike domains and apply these to a specifically constructed gearlike domain.

We note that certain applications in electrostatics and hydrodynamics require solution domains with rounded corners, since sharp corners give rise to infinite field strengths and infinite velocities which physically correspond to electrostatic breakthrough and turbulence, respectively.

Throughout the paper we will let \mathcal{D} denote the open unit disk, $\{z \mid |z| < 1\}$. Also, we will let \mathcal{T} denote the boundary of \mathcal{D} , $\{z \mid |z| = 1\}$.

If g is analytic on \mathcal{D} and piecewise continuous on \mathcal{T} , then we will say that g is *halb-schlicht* on \mathcal{T} if for each point z of continuity of g on \mathcal{T} there exists a neighborhood N_z of z such that g is univalent on $N_z \cap \mathcal{D}$.

2. Representation

A function g analytic on \mathcal{D} and vanishing only at $z = 0$ is said to be gearlike if g is locally univalent on \mathcal{D} , piecewise continuous and halb-schlicht on \mathcal{T} , and maps \mathcal{D} to a domain whose boundary consists of arcs of circles centered at the origin and segments of rays emanating from the origin. If g is, additionally, univalent on \mathcal{D} , then g is said to be univalently gearlike.

A domain \mathcal{G} is said to be gearlike if there exists a gearlike function f which maps \mathcal{D} onto \mathcal{G} . If \mathcal{G} is a simply connected domain containing 0 and if the boundary of \mathcal{G} consists entirely of arcs of circles centered at the origin and segments of rays emanating from the origin, then the Riemann mapping theorem guarantees the existence of a univalent gearlike function g mapping \mathcal{D} onto \mathcal{G} . Examples of gearlike domains are noted in Fig. 1.

Let g be gearlike and set $G = zg'/g$. The boundary behavior of g imposes the following (useful) constraints on G (see [4]).

Lemma. (i) Let γ be an arc on \mathcal{T} parametrized by $e^{i\theta}$ which maps under g to a segment of a ray emanating from 0. Then G is pure imaginary on γ . Furthermore, $\text{Im } G(e^{i\theta}) > 0$ on γ if and only if $|g(e^{i\theta})|$ is strictly decreasing on γ .

(ii) Let λ be an arc on \mathcal{T} parametrized by $e^{i\theta}$ which maps under g to an arc of a circle centered at 0. Then G is real-valued on λ . Furthermore, $\text{Re } G(e^{i\theta}) > 0$ on λ if and only if $\text{Arg } g(e^{i\theta})$ is strictly increasing on λ .

Proof. It suffices to note that for $z = e^{i\theta}$ that

$$i \frac{zg'(z)}{g(z)} = \frac{\partial}{\partial \theta} \log g(z) = \frac{\partial}{\partial \theta} \log |g(z)| + i \frac{\partial}{\partial \theta} \text{Arg } g(z).$$

The lemma immediately implies that G maps \mathcal{D} to a region bounded by line segments lying on the real and imaginary axes.

Using the Schwarz reflection principle it can be shown that g , gearlike, can be extended over \mathcal{T} to a function analytic and locally univalent on the entire complex plane except at a finite number of points z_j on \mathcal{T} . Since g is halb-schlicht on \mathcal{T} , then at the exceptional points z_j one of the following must occur:

- (i) $g(z_j)$ will be a 'true' corner point of $g(\mathcal{D})$, i.e., $g(z_j)$ will be a boundary point of $g(\mathcal{D})$ where a radial segment on the boundary joins a circular arc on the boundary.
- (ii) $g(z_j)$ will be the (finite) tip of a radial or circular slit in $g(\mathcal{D})$.
- (iii) g is infinite at z_j and has an algebraic singularity there.

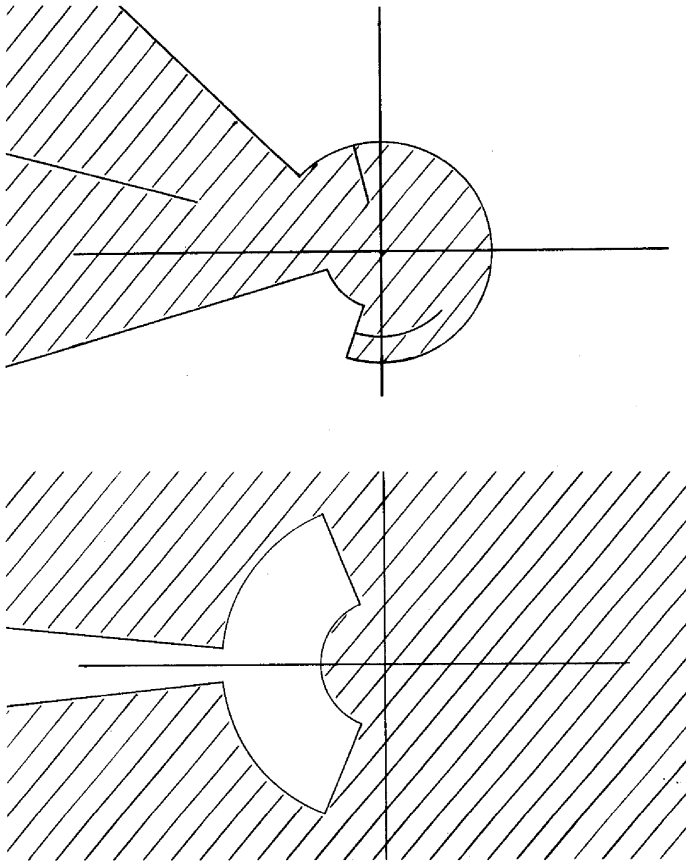

Fig. 1.

If (i) holds, then the interior angle α at $g(z_j)$ must be either $\frac{3}{2}\pi$ or $\frac{1}{2}\pi$, since g is gearlike. In either case g must have a local expansion at z_j of the form $g(z) = g(z_j) + A_j(z - z_j)^{\alpha/\pi} + \dots$ and G must have an expansion of the form $G(z) = B_j(z - z_j)^{\alpha/\pi - 1} + \dots$.

If (ii) holds, then the interior angle at $g(z_j)$ is 2π . Thus, g has a local expansion at z_j of the form $g(z) = g(z_j) + A_j(z - z_j)^2 + \dots$ and G has an expansion of the form $G(z) = B_j(z - z_j) + \dots$.

Finally, if (iii) holds, then G will have a local expansion at z_j of the form $G(z) = B_j(z - z_j)^{-1} + \dots$.

Using the above observations and employing an argument similar to the one given by Goodman [4], we establish the following representation theorem for gearlike functions.

Theorem. *Let g be gearlike. Then g satisfies*

$$\frac{zg'(z)}{g(z)} = \prod_{j=1}^m (1 - \bar{\xi}_j z)^{\alpha_j} / \prod_{k=1}^n (1 - \bar{\eta}_k z)^{\beta_k} \quad (1)$$

where: (A) the ζ_j, η_k are all distinct points on \mathcal{T} , (B) the α_j, β_k are all either $\frac{1}{2}$ or 1 (C) $\sum_{j=1}^m \alpha_j = \sum_{k=1}^n \beta_k$, and (D) $\sum_{j=1}^m \alpha_j \text{Arg } \zeta_j - \sum_{k=1}^n \beta_k \text{Arg } \eta_k \equiv 0 \pmod{\pi}$ Conversely, if g satisfies (1), then g is gearlike.

Proof. Suppose that g is gearlike. Set $G = zg'/g$. Then there exist distinct ζ_j, η_k on \mathcal{T} , powers α_j, β_k all either $\frac{1}{2}$ or 1 such that

$$Q(z) = G^2(z) \prod_{k=1}^n (1 - \bar{\eta}_k z)^{2\beta_k} / \prod_{j=1}^m (1 - \bar{\zeta}_j z)^{2\alpha_j}$$

satisfies the following properties: (a) Q is analytic on $\mathcal{D} \cup \mathcal{T}$; (b) $\text{Arg } Q$ is piecewise constant on \mathcal{T} ; (c) $Q(0) = 1$. It follows that Q is identically constant and, hence, the representation (1) for g holds modulo conditions (C) and (D). If, however, (C) were not satisfied, then a straightforward analysis would show that $\text{Arg } G$ was not piecewise constant on \mathcal{T} , contradicting the conclusion of the lemma. The lemma immediately implies that (D) holds

Conversely, suppose g satisfies (1). Then, it is easily seen [3] that g is analytic and locally univalent on \mathcal{D} , vanishing only at $z \equiv 0$, and piecewise continuous and halb-schlicht on T . Furthermore, conditions (C) and (D) and the lemma imply that g maps \mathcal{D} to a domain bounded by arcs of circles centered at 0 and segments of rays emanating from 0.

3. Rounding corners

Let g be gearlike and set $G = zg'/g$. Let z_0 be a point on \mathcal{T} which is an exceptional point, as described above, for the locally univalent, analytic continuation of g across \mathcal{T} . The corner in the domain $g(\mathcal{D})$ which corresponds to z_0 must be one of two types: (1) $g(z_0)$ is the junction point of a radial segment and a circular arc bounding $g(\mathcal{D})$; (2) $g(z_0)$ is the (finite) tip of a slit in $g(\mathcal{D})$ or g is infinite at z_0 and has an algebraic singularity there. For each of the above cases we shall construct a perturbation for G which will induce a local rounding for the corner at $g(z_0)$ and which will not alter the radial and circular boundary behavior of g elsewhere. For convenience in the discussion we will write $z_0 = e^{i\theta_0}$.

3.1. Junction of a radial segment and a circular arc

Since, locally, g maps \mathcal{T} on one side of z_0 to a radial line segment and the other side of z_0 to an arc of a circle centered at 0, the interior angle α for $g(\mathcal{D})$ at $g(z_0)$ must be either $\frac{3}{2}\pi$ or $\frac{1}{2}\pi$. Also, locally, G must map \mathcal{T} on one side of z_0 to a segment on the imaginary axis and on the other side of z_0 to a segment on the real axis.

Case 1. $\alpha = \frac{3}{2}\pi$. Since $\alpha > \pi$, $g'(z) \rightarrow 0$ as $z \rightarrow z_0$; thus, locally at z_0 we can write

$$zg'(z)/g(z) = G(z) = H(z)\sqrt{z - z_0} \tag{2}$$

where H is analytic and non-vanishing at z_0 . To round the corner at $g(z_0)$ we perturb (2) by the factor

$$T_1(z_0, z) = \frac{a \left(\frac{e^{-irz} - e^{irz_0}}{z - z_0} \right)^{1/2} + b \left(\frac{e^{is_z} - e^{-is_z_0}}{z - z_0} \right)^{1/2}}{\left[a^2 + 2ab \cos\left(\frac{r+s}{2}\right) + b^2 \right]^{1/2}}$$

where a, b, r, s are all positive parameters. (Each square root is defined using the principal branch of the logarithm.) Then, if g_* and G_* are defined by

$$zg'_*(z)/g_*(z) = G_*(z) = H(z)\sqrt{z-z_0}T_1(z_0, z),$$

and if r, s are chosen sufficiently small so that on the set

$$C(\theta_0, r, s) = \{e^{i\theta} | \theta_0 - 2s < \theta < \theta_0 + 2r\} \tag{3}$$

g' vanishes only at z_0 , we claim that g_* has no corner on $C(\theta_0, r, s)$, i.e., g'_* does not vanish on $C(\theta_0, r, s)$, and that g and g_* have the same local radial or circular boundary behavior everywhere on $\mathcal{S} \setminus C(\theta_0, r, s)$.

Indeed, we note that $\sqrt{z-z_0}T_1(z_0, z)$ has a removable singularity at z_0 and is non-vanishing on \mathcal{S} . Furthermore, for $z = e^{i\theta}$

$$T_1(z_0, z) = \left[a \left(\frac{\sin \frac{1}{2}(\theta - \theta_0 - 2r)}{\sin \frac{1}{2}(\theta - \theta_0)} \right)^{1/2} + b \left(\frac{\sin \frac{1}{2}(\theta - \theta_0 + 2s)}{\sin \frac{1}{2}(\theta - \theta_0)} \right)^{1/2} \right] \times \left\{ \left[a^2 + 2ab \cos\left(\frac{r+s}{2}\right) + b^2 \right]^{1/2} \right\}^{-1}.$$

Thus, for $z \in \mathcal{S} \setminus C(\theta_0, r, s)$, $T_1(z_0, z)$ is real-valued, in fact positive. Hence, on $\mathcal{S} \setminus C(\theta_0, r, s)$ G and G_* are locally either both pure imaginary or both real, which implies the claim.

Case 2. $\alpha = \frac{1}{2}\pi$. Since $\alpha < \pi$, $|g'(z)| \rightarrow \infty$ as $z \rightarrow z_0$. Thus, locally at z_0 we can write

$$zg'(z)/g(z) = G(z) = H(z)/\sqrt{z-z_0} \tag{4}$$

where H is analytic and non-vanishing at z_0 . To round the corner at $g(z_0)$ we perturb (4) by the factor

$$T_2(z_0, z) = 1/T_1(z_0, z).$$

Then, a similar analysis (to the case $\alpha = \frac{3}{2}\pi$) will show that g_* defined by

$$zg'_*(z)/g_*(z) = (H(z)/\sqrt{z-z_0})T_2(z_0, z)$$

does not have a corner on $C(\theta_0, r, s)$ and that g and g_* have the same local boundary behavior on $\mathcal{S} \setminus C(\theta_0, r, s)$.

3.2. Tip (finite) of a slit or infinite algebraic singularity

We first consider the case where $g(z_0)$ is the finite tip of either a radial or circular slit in $g(\mathcal{D})$. Clearly, the interior angle α for $g(\mathcal{D})$ at $g(z_0)$ is 2π . If the slit is radial, then G , locally at z_0 , must map \mathcal{S} onto segments on the imaginary axis and must change sign from one side of z_0 to the other. Similarly, if the slit is circular, then locally (at z_0) G maps \mathcal{S} to segments on the real axis and changes sign from one side of z_0 to the other. In either case, since $\alpha > \pi$, $g'(z) \rightarrow 0$ as $z \rightarrow z_0$ and $G(z) \rightarrow 0$ as $z \rightarrow z_0$. Thus, we have

$$zg'(z)/g(z) = G(z) = H(z)(z-z_0) \tag{5}$$

where H is analytic and non-vanishing at z_0 . To open up the slit ending at $g(z_0)$ and round the

tip we perturb (5) by the factor

$$T_3(z_0, z) = \frac{a + b \left[\left(\frac{e^{-ir}z - e^{ir}z_0}{z - z_0} \right) \left(\frac{e^{is}z - e^{-is}z_0}{z - z_0} \right) \right]^{1/2}}{\left[a^2 + 2ab \cos\left(\frac{r-s}{2}\right) + b^2 \right]^{1/2}}$$

where a, b, r, s are all positive parameters. (The square root is defined using the principal branch of the logarithm.) Then, if g_* and G_* are defined by

$$zg'_*(z)/g_*(z) = G_*(z) = H(z)(z - z_0)T_3(z_0, z)$$

and if r, s are chosen sufficiently small so that g' vanishes on $C(\theta_0, r, s)$ (given in (3)) only at z_0 , we claim that g_* has no corner on $C(\theta_0, r, s)$ and that g and g_* have the same local radial or circular boundary behavior everywhere on $\mathcal{S} \setminus C(\theta_0, r, s)$.

Clearly, $(z - z_0)T_3(z_0, z)$ has a removable singularity at z_0 . Furthermore, for $z = e^{i\theta}$

$$T_3(z_0, z) = \frac{a + b \left[\left(\frac{\sin \frac{1}{2}(\theta - \theta_0 - 2r)}{\sin \frac{1}{2}(\theta - \theta_0)} \right) \left(\frac{\sin \frac{1}{2}(\theta - \theta_0 + 2s)}{\sin \frac{1}{2}(\theta - \theta_0)} \right) \right]^{1/2}}{\left[a^2 + 2ab \cos\left(\frac{r-s}{2}\right) + b^2 \right]^{1/2}}$$

Thus, for $z \in \mathcal{S} \setminus C(\theta_0, r, s)$ $T_3(z_0, z)$ is real-valued, in fact, positive. From here the claim follows as before.

The final case to be considered is if g is infinite at z_0 and has an algebraic singularity there. In this case we can write, as noted previously,

$$zg'(z)/g(z) = G(z) = H(z)/(z - z_0) \quad (6)$$

where H is analytic and non-vanishing at z_0 . We can perturb (6) so as to eliminate the singularity of g at z_0 and retain outside of a set $C(\theta_0, r, s)$ the local boundary behavior of g by using the factor

$$T_4(z_0, z) = 1/T_3(z_0, z).$$

If we define g^* by

$$zg'_*(z)/g_*(z) = (H(z)/(z - z_0))T_4(z_0, z),$$

then g^* will have the required properties.

4. Omitted area problem

In this section we give an application of our work to the omitted area problem. Let \mathcal{S} be the class of univalent, analytic functions f on \mathcal{D} normalized by $f(z) = z + a_2z^2 + \dots$. The omitted area problem, originally posed by Goodman [5], is to determine the maximum area within the unit disk which can be omitted from the range of a function in \mathcal{S} . Formally, if $f \in \mathcal{S}$ and A_f is the area of $f(\mathcal{D}) \cap \mathcal{D}$ ($\pi - A_f$ is the omitted area), then the problem posed by Goodman and

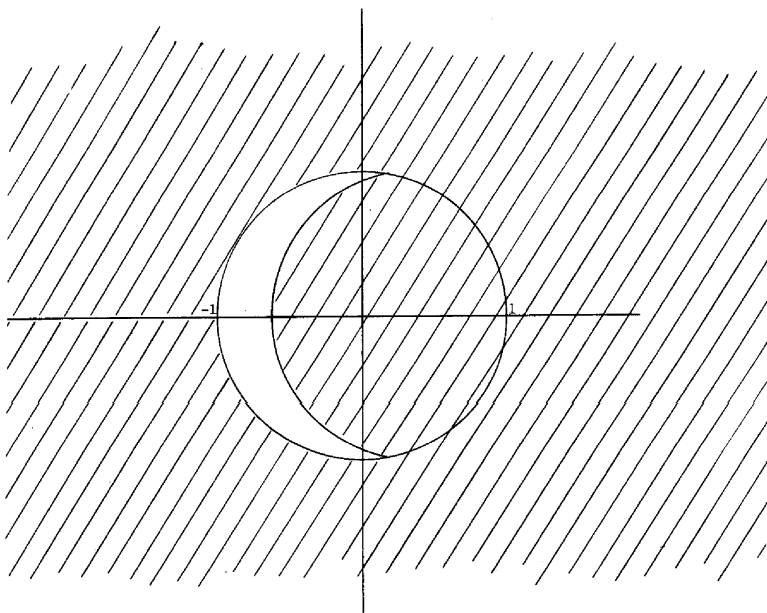

Fig. 2.

reposed by Brannen as Problem 6.35 of [1] is to find

$$A^* = \inf_{f \in \mathcal{S}} A_f. \tag{7}$$

An argument can be given, employing the semi-continuity of area as a functional, to show that an extremal function for the problem exists and, hence, the inf in (7) can be replaced by min.

Goodman showed that $0.5\pi \leq A^* < 0.7728\pi$. The upper bound which he obtained was generated by a domain of the type in Fig. 2. Later, Goodman and Reich [6] gave an improved lower bound of 0.62π for A^* .

The first author [2] has shown, using variational techniques and subordination theory, that (up to rotation) the extremal function f for the omitted area problem must satisfy the following conditions (with an assumption of piecewise continuity of f' on \mathcal{S}):

- (i) $f(\mathcal{D})$ is circular symmetric, see [7] (w.r.t. the positive real axis);
- (ii) There exist $0 < \theta_1 < \theta_2 < \pi$ such that
 - (a) f maps the boundary arc $\{e^{i\theta} \mid 0 < \theta < \theta_1\}$ onto the radial half-line $(-\infty, -1)$;
 - (b) f maps the boundary arc $\{e^{i\theta} \mid \theta_1 < \theta < \theta_2\}$ onto a circular subarc of \mathcal{S} starting at -1 ;
 - (c) f maps the boundary arc $\{e^{i\theta} \mid \theta_2 < \theta < \pi\}$ onto a curve γ which joins \mathcal{S} to the point $f(-1)$ on the interval $(-1, 0)$ and which has the property that the modulus of the normal to γ is constant, except possibly on subarcs of γ lying on $(-1, 0)$.

The description in (i)–(ii) of the boundary behavior of the extremal function for the omitted area problem suggests a motivation for considering symmetric gearlike domains \mathcal{G} of the type given in Fig. 3.

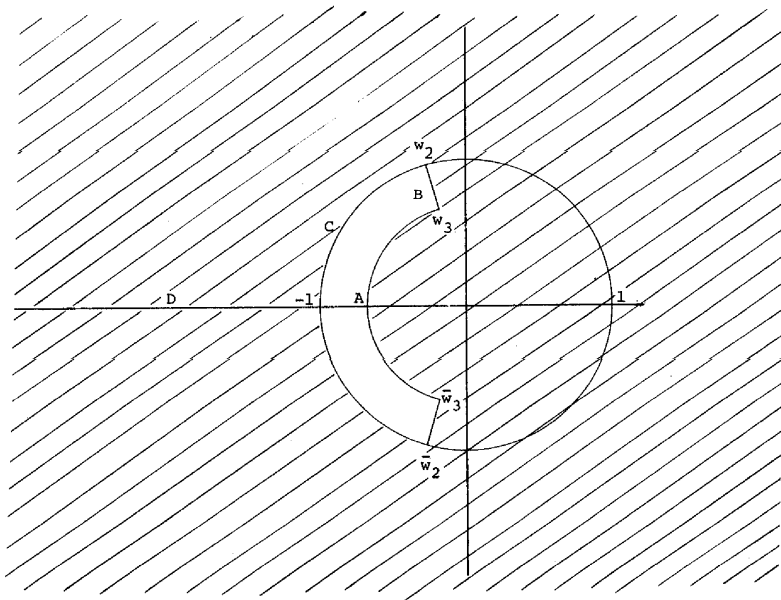

Fig. 3.

Let g be the associated gearlike function which maps \mathcal{D} to G . Since the mapping radius of g , i.e., the modulus of $g'(0)$, varies continuously, in fact, monotonically, with the argument of the side B and with the modulus of point A , then for each side B with the argument between 0 and π an inner modulus point A can be chosen so that $g'(0) = 1$ or, alternatively, for each point A with modulus between $\frac{1}{4}$ and 1 a side B can be chosen so that $g'(0) = 1$. Suppose that A and B are chosen so that $g'(0) = 1$. Then g satisfies (i) and parts (a)–(b) of (ii). However, because of the corners in \mathcal{G} at w_2 and w_3 , g cannot satisfy part (c) of (ii) and, hence, g can not be the extremal function for the omitted area problem. Heuristically, one expects that if one could eliminate the corners in \mathcal{G} at w_2 and w_3 (and symmetrically at \bar{w}_2 and \bar{w}_3), one could produce (after renormalization) a function with increased omitted area in \mathcal{D} and thus move from g towards the extremal function for the problem.

It is easily seen that g (for \mathcal{G} in Fig. 2) has a representation of the form

$$\frac{zg'(z)}{g(z)} = \left[\frac{p_2(z)p_3(z)}{p_0(z)p_1(z)} \right]^{1/2} \quad (8)$$

where $p_j(z) = 1 - 2(\cos \theta_j)z + z^2$, $j = 0, 1, 2, 3$ with $0 = \theta_0 < \theta_1 < \theta_2 < \theta_3 < \pi$. Let g be the solution of (8) which satisfies $g'(0) = 1$. Since the modulus of the outer arc C and the argument of the infinite ray D vary continuously with the parameters in (8), then in order to satisfy the conditions (a)–(b) of (ii) two of the parameters in (8) must be constrained by the implicit equations $\text{modulus}(\text{arc } C) = 1$ and $\text{argument}(\text{ray } D) = \pi$. Thus, with the constraints, (8) describes a one-parameter family of gearlike functions mapping to domains \mathcal{G} of the type shown in Fig. 3.

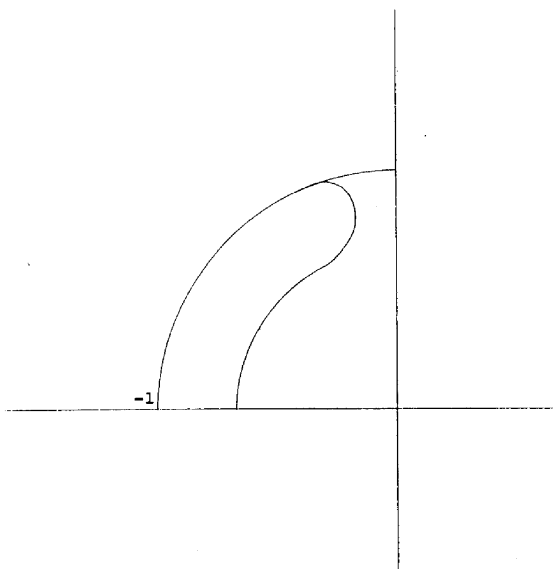

Fig. 4.

If, specifically, θ_1 is set at 0.314159 and θ_2 and θ_3 are subjected to the constraints of parts (a)–(b) in (ii), then the constructed g maps \mathcal{D} to a gearlike domain \mathcal{G} (of the type in Fig. 3) with inner modulus at A of 0.68057, boundary argument at B of 1.8237 and covered area $A_g = 0.7748\pi$.

Let z_j be the preimages under g of w_j , $j = 2, 3$. If we perturb the corners at w_2 and w_3 (and symmetrically at \bar{w}_2 and \bar{w}_3) to induce rounding locally, then we introduce 8 parameters into (8), 4 for each corner. The equation for the perturbed g_* takes the form

$$\frac{zg'_*(z)}{g_*(z)} = \frac{zg'(z)}{g(z)} T_1(z_2, z) \overline{T_1(z_2, \bar{z})} T_1(z_3, z) \overline{T_1(z_3, \bar{z})}. \tag{9}$$

Again, the modulus of the outer arc and the argument of the infinite ray vary continuously as functions of the 11 parameters in (9). An initial choice of parameters $\theta_1 = 0.314$ (θ_2 and θ_3 constrained so that conditions (a)–(b) of (ii) are satisfied), $r_2 = 0.1$, $s_2 = 0.2$, $a_2 = 0.5$, $b_2 = 1.0$, $r_3 = 0.2$, $s_3 = 0.3$, $a_3 = 1.0$ and $b_3 = 1.0$ produces a simple perturbation g_1 of g for which the covered area decreases to $A_{g_1} = 0.76906\pi$. (See Fig. 4, showing the portion of the boundary in the upper half plane.)

Using a grid search over the nine free parameters in (9) to maximize the omitted area, we obtained a best area function g_2 with $A_{g_2} = 0.759995\pi$ and parameters $\theta_1 = 0.305034$, $r_2 = 0.0352$, $s_2 = 0.0316$, $a_2 = 13.1705$, $b_2 = 0.0005$, $r_3 = 0.3284$, $s_3 = 0.3278$, $a_3 = 0.9025$, $b_3 = 1.9498$. See Fig. 5, depicting a portion of the domain arising from this last choice of parameters. We note the unexpected result of the geometrical shift from Fig. 4 to a less visibly rounded corner for the domain giving the best obtained bound. However, it does approach the domain used by Goodman (see Fig. 2), which may explain the proximity of his bound to ours. Our work suggests

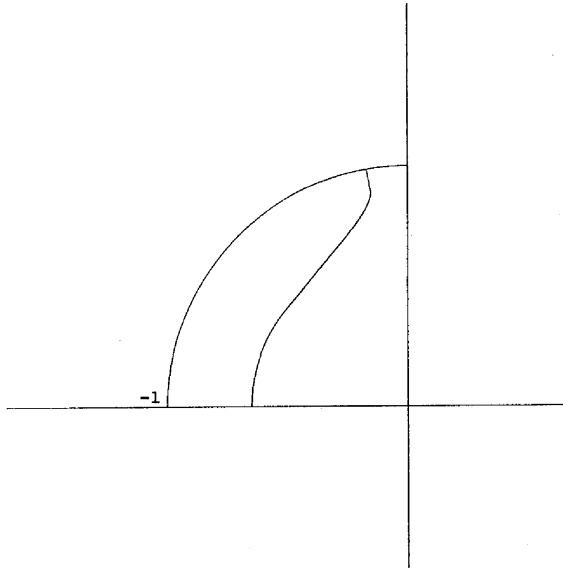

Fig. 5.

that the actual value of A^* is approximated to within 0.01π by the upper bound obtained here in contrast to the imprecise lower bound given in [6].

References

- [1] J.M. Anderson, K.F. Barth and D.A. Brannen, Research problems in complex analysis, *Bull. Lond. Math. Soc.* **9** (1977) 129–162.
- [2] R.W. Barnard, On the omitted area problem, in preparation.
- [3] D.M. Campbell and K. Pearce, Generalized Bazilevic functions, *Rocky Mountain J. Math.* **9** (1979) 197–226.
- [4] A.W. Goodman, Conformal mapping onto certain curvilinear polygons, *Univ. Nac. Tucuman A* **13** (1960) 20–26.
- [5] A.W. Goodman, Note on regions omitted by univalent functions, *Bull. Amer. Math. Soc.* **55** (1949) 363–369.
- [6] A.W. Goodman and E. Reich, On the regions omitted by univalent functions II, *Canad. J. Math.* **7** (1955) 83–88.
- [7] W.K. Hayman, *Multivalent Functions* (Cambridge University Press, New York, 1967).
- [8] P. Henrici, *Applied and Computational Complex Analysis, Vol. 1* (Wiley-Interscience, New York, 1974).